

Instructor's Manual

SEFRS[®] **SX405**[®] Emergency Fracture Response System

J. M. Fikes, BSN, MSN • A.G. Borschneck, M.D. • Edited By: A.L. Borschneck, BA



Table of contents

Instruction Guidelines	1
<hr/>	
Section One:	
Introduction	2
Parts and Accessories	3
<hr/>	
Section Two:	
Anatomy and physiology and treatment of femoral fractures	4
<hr/>	
Section Three:	
SEFRS [®] applications for splinting femoral fractures	13
Features and Benefits of the SX405 [™] Emergency Traction Splint	18
<hr/>	
Section Four:	
Components	21
<hr/>	
Section Five:	
Questions and answers SEFRS [®] application for splinting and treatment of femoral fractures	24
Indications: SX405 [™] Traction splints are indicated for use on proximal third and mid-shaft femoral fractures. Cleaning instructions	30
<hr/>	
Section Six:	
Practical examinations (i) SEFRS [®] SX405 [™] Traction Splint	31
SX405 [™] SEFRS [®] Adaptor [™] Student Exercise	40
<hr/>	
Section Seven:	
SX405 [™] SEFRS [®] Adaptor [™] for the treatment of all body fractures	42
Features and Benefits of the SX405 [™] SEFRS [®] Adaptor [™]	48
<hr/>	
Section Eight:	
Practical examinations (ii) SX405 [™] SEFRS [®] Adaptor [™]	
The all fracture response system	49

Additional Handouts

Handouts:

User's Handbook,
Why Traction, Traction
Force Challenge,

Emergency Orthopedics:

The Extremities,
USA ICD9 Projections,
Suggested Reading,
Overhead Projections

Minto Research & Development, Inc.

Manufacturers of:

SX405[™], **SEFRS**[®] **Adaptor**[™], Sager[®]
Emergency Traction Splints are registered
trademark of Minto Research &
Development, Inc.

Minto Research & Development, ©1998/10

MINTO[™]
Research & Development, Inc.

Minto Research & Development, Inc

20270 Charlanne Drive
Redding, CA, USA, 96002-9223

Tel: 1. 800. 642. 6468
530. 222. 2373

Fax: 530. 222. 0679

E-Mail: MINTORD@aol.com

www.sagersplints.com

Section One:

Instruction guidelines

The following lecture guidelines were developed to assist ALS and BLS Instructors in their endeavor to introduce the **SEFRS**[®] **SX405**[®] Emergency Fracture Response System to students participating in EMT and Nursing/ Paramedic programs. These guidelines are only intended for use as a basic reference tool. Please defer to federal, state, and local medical protocol for definitive analysis and guidelines.

Introduction to Sager Emergency Traction Splints:

The complete fracture response system

The **SEFRS SX405**[®] Emergency Fracture Response System has been medically engineered to accommodate First Responder treatment with a fast, easy, fail-safe compact traction device, a **SX405 Adaptor**[™] (for treatment of most fracture types), an extensive Tensor Cravat System, as well as the multi-versatile **SAM**[®] **SPLINTS**. Combined, these three items cover all of today's extreme rescue environments.

Instructors:

- Demonstrate the application for treatment of a single and bilateral femoral fracture on a volunteer or mannequin.
- Demonstrate the application of splints on all limb fractures and joint fracture dislocations as outlined in the **SEFRS**[®] Sager Emergency Fracture Response System Brochure.
- Have each class member practice with the splint(s) until they demonstrate to you that they have mastered good splinting techniques.
- Ask if there are any questions regarding the use of **SEFRS**[®] fracture applications and address these in accordance with the provided instructional materials (and state/local medical protocol). If you are unsure of the answer to a question, record it and contact your local or state education service for the answer.
- Review all materials and discuss various application scenarios.
- Split the class into three equal groups. Have one group write the written test, one group practice with the splint(s) and one group take the practical test(s). Rotate through the groups until each student has (1) practiced with the splint, (2) demonstrated they can apply it correctly, and (3) taken the written exam.
- Mark the written exam. Students who fail the written exam should review the material and retake the exam.

Provide handouts of:

- 1 Why Traction (Reprint from JEMS)
- 2 Traction Force Challenge (Reprint from EMS Magazine)
- 3 Emergency Orthopedics: The Extremities (Reprint)
- 4 USA ICD9 Projections (1997)

Instructors Note:

■ Trials using the **SEFRS SX405**[®] traction splint; in practice situations should be undertaken with the "patient" wearing loose clothing and jeans so that natural genital mobility can take place.

■ Demonstrate the correct application of the Sager traction Splint – 1 person application in under 2 minutes!

■ For treatment of all other fracture types using the **SX405 Adaptor**[™], we have provided a second practical exam for your convenience.

Model SEFRS SX405[®], the complete fracture system
comes complete with all accessories required for use and include:

- 1 One **SEFRS SX405[®]** Extreme Compact Bilateral Emergency Traction Splint
- 2 One Ischial Perineal Cushion (saddle)
- 3 One Abductor Bridle (thigh strap)
- 4 One Carry Case
- 5 One Pedal Pinion (figure eight strap)
- 6 Two Malleolar Harnesses (ankle harnesses)
- 7 One **SX405 Adaptor[™]**
- 8 Two colour coded **SX405[®]** Extender Shafts
- 9 Two 2"x8" Tensor Cravat
Two 2"x10" Tensor Cravat
Two 2"x18" Tensor Cravat
Two 2"x24" Tensor Cravat
- 10 Two 4"x18" Tensor Cravat
Two 4"x24" Tensor Cravat
- 11 Two 6"x18" Tensor Cravat
One 6"x24" Tensor Cravat
One 6"x32" Tensor Cravat

*Combine cravats to increase length if needed (eg. use a 24" and 32" for full body wrap).

- 13 Red and Black End Caps
- 14 Shoulder Strap/Sling
- 15 Six Security Cravats

SAM[®] SPLINTS

- 16 Two 36" C-Curve Sam Splints
- 17 Five Sam Finger Splints

Caution: This product contains Natural Rubber Latex, which may cause allergic reactions.



(PowerPoint #9)



Section Two:

Anatomy, physiology and treatment of femoral fractures



The human pelvis is a closed bony ring that is strong and massively constructed. It is the foundation for the torso and provides support for the lower limb attachment and locomotion. It is shaped so that the ischial tuberosity forms a platform for sitting in an upright position. This occurs because the ischial tuberosity is the most distal part of the pelvis. When the legs are flexed anteriorly, all the weight of the body can rest unencumbered on the ischial tuberosities.

(Review PowerPoint tutorial overview)

Each tuberosity is medial to the shaft of the femur, and is located half the distance between the midline symphysis pubis and the femoral shaft. They form the base-line of the uro-genital triangle which slopes anterior and cephalad. The external genitalia in both sexes are attached at the apex of the uro-genital triangle, and because of this both sexes can sit straddling seats and saddles without discomfort or injury.

The largest muscle mass in the human body is located surrounding the length of the femur. When fracture of the femur occurs, it can result in:

- Laceration of arteries, veins and nerves at the site of the fracture.
- Severe muscle spasms resulting in bone fragment overriding, deformity and shortening of the limb.
- Decreased tissue pressure – resulting in further bleeding and shock, as well as severe pain.

In addition, spasm of the psoas and piriformis muscles acting on the proximal fragment of the femur may cause a flexion, abduction and external rotation deformity.

fig 1

Skeletal relationship between the pelvis and femur in AP position. Note that the ischial tuberosity is half the distance from mid-line to femur.

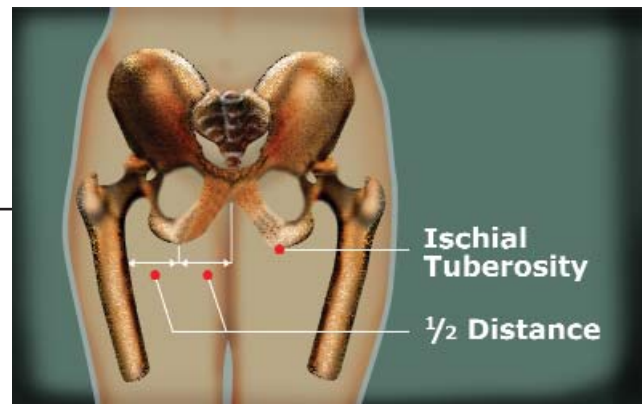

fig 2

Ischial tuberosity and femur are on the same plane. Note how the ischial tuberosity protrudes no more than 1-2 cms, below the shaft of the femur when patient is supine



(PowerPoint #2)

Comparative application of traction

Application of traction breaks the spasm and eliminates much of the pain. It also causes alignment of the bone fragments and subsequent increased tissue pressure. This reduces and controls bleeding and shock, and prevents further nerve, vascular and tissue damage. It is clear that properly applied traction and immobilization of a fractured femur helps control shock and reduces mortality.

The traction needed to break the spasm of muscles associated with a fractured femur is a product of the traction force and the length of time it is applied. A very large traction force only needs to be applied a short while for muscle fatigue and relaxation of the spasm to occur. Large traction forces, generally in excess of 30 to 50 pounds can in some cases control spasm in a few seconds. However, there is a risk with this mode of traction. It may result in nerve, vascular, muscle and soft tissue injury, as well as over-extension of bone fragments. Gentle traction, "... the amount of pull required to accomplish this (traction) will vary but rarely exceed 15 pounds. This is gentle traction, and the least amount of force necessary is the amount that should be employed" (American Academy of Orthopedic Surgeons, Emergency Care and Transport of the Sick and Injured, Third Edition, George Banta Co., Inc., 1981, San Antonio, TX, pg.:142)

Skeletal comparisons between **SEFRS**[®] and Hare

fig 3

Hare Ischial Pad Splint. Angle of malalignment is 51 degrees.



fig 4

SEFRS[®] Traction Splints provide near perfect alignment.

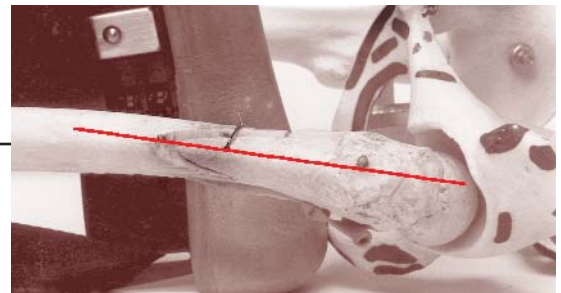

fig 5

SEFRS[®] Near-perfect alignment when applied.



Safe traction

Safe traction for field use should be traction in a known amount prescribed by protocol or a medical consultant. It should also be traction that is dynamic in nature using a resilient member that permits graded reduction of traction force as the muscle spasm decreases and leg length increases. It should avoid the pitfalls of rope, weight and pulley traction – which is a constant and unrelenting force that can result in over-extension of the bone elements. This method is more conducive to a hospital environment where it can be monitored at length, under the care and supervision of an Orthopedic or other Medical Consultant.

Static traction, as provided by drum and crank arrangements should also be avoided. The traction is not quantifiable and, most importantly, can be completely lost if leg spasm stops and the limb lengthens. This traction force exists only for a set length between points of traction and countertraction. It also necessitates constant monitoring and resetting of traction – leading to further distraction of bone elements, and/or needless increase in pain. In addition, uneven forces in lifting and carrying, or simply moving a patient can double or triple the forces against the injured limb. This drawback is commonly associated with most Ischial Pad splints that promote the use of static traction arrangements.

Common femoral fractures versus splinting systems

In 1997, the projected potential of U.S. femoral fracture hospital admissions totaled 474,551 (USA ICD9 Projections, Internet). Of these, proximal third fractures accounted for 84% or 399,484 of total hospital admissions, while mid shaft fractures accounted for 9% or 41,012 of all admissions. Together, these two fracture types amounted to an estimated 93% of all hospital admissions. The remaining 7% (34,055) of fracture types indicates traction was not needed or contraindicated.

SEFRS[®] Traction Splints are indicated for treatment in all proximal third and mid shaft fractures. In other words in 1997 alone, Sager Splints had the capability and potential to treat 93% of all projected femoral fractures. Conversely, Ischial Pad splints are contraindicated in the treatment of proximal third fractures, and thus are only indicated for treatment of mid shaft fractures (roughly 9% of all femoral fractures).

A major concern relating to proximal third femoral fractures is the proximity of the sciatic nerve. The sciatic nerve exits the pelvis behind the femoral head and lies along the postero-medial edge of the shaft of the femur. Improper traction splinting of proximal third fractures may result in unnecessary nerve injury. These concerns do not apply to **SEFRS**[®] Traction Splints because of the unique design of the Ischial Perineal Cushion.

fig 6

Pelvis, femur and the sciatic nerve

(PowerPoint #3)

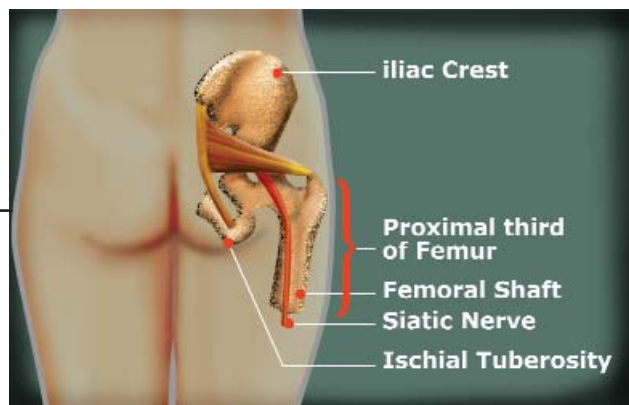

Consider the anatomy of the pelvis and femur. In an AP view, the ischial tuberosity is located about half the distance from the mid-line to the femur. In a lateral view, the ischial tuberosity's lower edge is no more than 1/2" to 1" below the shaft of the femur.

A true Thomas Full Ring or Half Ring Splint, properly sized, curves up to press against the ischial tuberosity medial to the shaft of the femur while the bottom of the ring is well below the lower edge of the femoral shaft. Ischial Pad splints, although often referred to as half ring splints, are not true half ring splints. Ischial Pad splints are really only a slightly dished padded bar at right angles to the femoral shaft of the femur. The bars/pads are usually elevated on pedestals that can range in height from 1 3/4" to 3 1/2" high (the same adult elevations are seen in pediatric models which unfortunately, have not been resized for pediatric patients). In order to hook onto the ischial tuberosity and provide countertraction, these bars/pads can push up on the femoral shaft resulting in an undesirable malalignment of the injured Limb. This malalignment is exaggerated in pediatric patients!

Conversely, **SEFRS**[®] Ischial Perineal Cushion was designed to impinge on the ischial tuberosity medial to the shaft of the femur and thus provide the same action as a Thomas Full Ring Splint. By design, the **SEFRS**[®] is anatomically engineered to avoid pressure against the proximal third of the femur and the sciatic nerve.



fig 7

Adult and Pediatric Ischial Pad Splints – side by side.

Note how the ischial pads are the same height. 3 1/2" at the highest point and 2 1/2" at the lowest point.

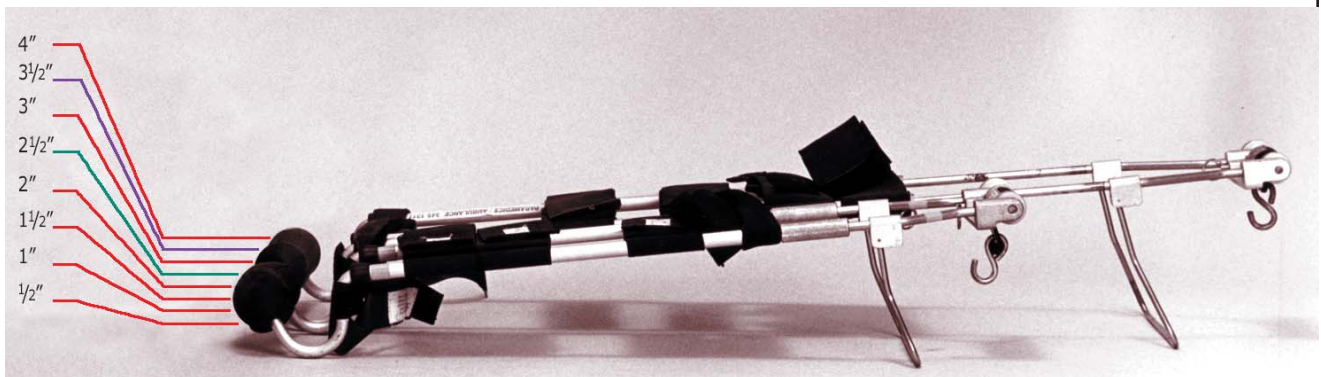

Summary

SEFRS[®] Emergency Traction Splints are the most anatomically correct traction splints available on the world market today. They apply countertraction against the ischial tuberosity medial to the shaft of the femur in a manner consistent with the original Thomas Full and Half Ring Splints. This is the same manner of traction and countertraction applied to patients in operating room theatres undergoing surgical reductions and repair. As with surgical procedures, **SEFRS**[®] application of traction avoids point pressure on the sciatic nerve and related vascular structures – in the critical proximal third of a femoral fracture. This same feature makes the Sager indicated for treatment in 93% of all femoral fractures!

SEFRS[®] Splints also avoid the pitfalls of rope, weight and pulley traction, as well as the hazards associated with drum and crank arrangements. They provide “gentle” quantifiable traction that is dynamic in nature. As such, the **SEFRS**[®] revolutionary design permits graded reduction of the traction force as the muscle spasm decreases and the leg length increases. The “Quantifiable” feature enables First Responders (for the first time ever) to document the traction force applied – a definite plus for medical legal purposes!

Cadaver Study: Comparison between Sager Emergency Traction Splints and Ischial Pad Traction Splints.

Abstract:

A traction and alignment comparison between the **SEFRS**[®] Traction Splint and the Hare Traction Splint was made on a cadaver with an exposed intertrochanteric femur fracture. Malalignment was observed when the Hare Traction Splint was applied. Acceptable alignment occurred with application of a **SEFRS**[®] Traction Splint.

SEFRS[®] Traction Splints' provide countertraction against the ischial tuberosity medial to the shaft of the femur – whereas Hare Traction Splints provided countertraction against the ischial tuberosity below the shaft of the femur. Pressure up against the femur with the Hare mechanism creates pressure and possible injury on the sciatic nerve and other intervening soft tissue structures. This does not occur with **SEFRS**[®] Traction Splints.

fig 8

Intertrochanteric femoral fracture with **SEFRS**[®] Traction Splint in place with 15lbs. of traction. Note alignment of fracture occurs and pressure on critical structures below the femoral shaft is absent.

- 1 Proximal femur greater trochanter
- 2 Distal femoral shaft. Note fracture alignment

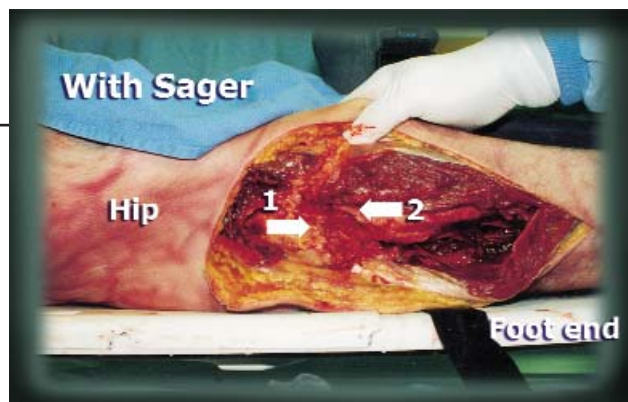

fig 9

Intertrochanteric femoral fracture with Hare Traction Splint in place with rope, 15lbs. weight and pulley for traction. Note femur is pushed up into malalignment and sciatic nerve and vascular structures are pushed up into fracture site.

- 1 Distal femoral shaft
- 2 Proximal femoral fragment externally rotated
- 3 Approximate site of sciatic nerve.



(PowerPoint #5)

A complete copy of the preliminary report;

"Cadaver Study; Comparison between Sager[®] Traction Splints and Ischial Pad Traction Splints" is available on request. Reprinted with permission from A.G. Borschneck, M.D.

Load Cell Study: Forces acting on an intact femur with a Hare Traction Splint and **SEFRS**[®] Traction Splint.

Abstract:

A Load Cell Study documenting forces acting on the proximal femur in real time was made comparing **SEFRS**[®] Traction Splint with the Hare Traction Splint¹. Range of force acting on the femur with **SEFRS**[®] Traction Splint was 0 - 2 lbs. Forces acting on the femur using a Hare Traction device varied from 12 - 71lbs.

Splint	Traction	Force Acting On femur
Hare Splint on a supine patient – no thigh strap applied.	No traction	Varies 5.1 to 25 lbs.
Hare Splint on supine patient – thigh strap applied.	No traction	Varies 6.8 to 27.7 lbs.
Hare Splint on supine patient – thigh strap applied.	15 lbs. traction	Varies 6.4 to 29.8 lbs.
Hare Splint on supine patient – thigh strap applied. Patient moved to a Semi-Fowler's position.	15 lbs. traction	Varies 8.8 to 48 lbs.
Hare Splint on supine patient – thigh strap applied. Patient moved to a sitting position.	15 lbs. traction	Varies 20.0 to 71.0 lbs.
Hare Splint on supine patient – thigh strap applied. Patient lifted and carried.	15 lbs. traction	Varies 3.1 to 34.9 lbs.
Hare Splint on supine patient – thigh strap applied. Patient moved to three quarter prone position.	15 lbs. traction	Varies 5.0 to 27 lbs.

A complete copy of the preliminary report "Load Cell Study; Forces acting on an intact femur with Hare Traction Splint and **SEFRS**[®] (Sager) Traction Splint" is available on request. Reprinted with permission from A.G. Borschneck, M.D.

Load Cell Study using a **SEFRS**[®] (Sager) Splint shows a maximum force of 1.2 lbs. acting on the femur with the patient in any position.

¹Study conducted using a Sager S304 Form III Bilateral Emergency Traction Splint

Cat Scan Study: The Ischial Tuberosity protrudes at most 1-2 cms below the level of the shaft of the femur.

Reprinted with permission from A.G. Borschneck, M.D.

fig 10

Survey Radiograph of CAT SCAN Study through pelvis and upper thigh of adult male.

Note: Male genitalia is not interposed between **SEFRS**[®] Ischial Perineal Cushion (splint cushion) and the ischial tuberosity.

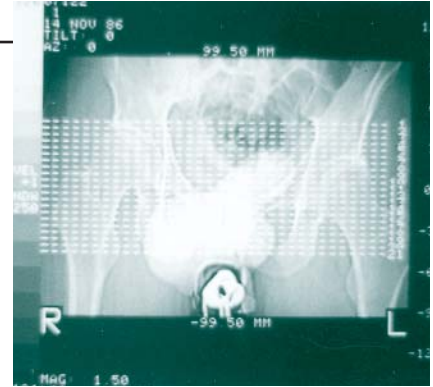

fig 11

Cross Section Cut #21 of CAT SCAN Survey of adult male.

Note: The ischial Tuberosity is a structure medial to the shaft of the femur and protrudes at most 1-2cms. below the level of the shaft of the femur.

1-2 cm

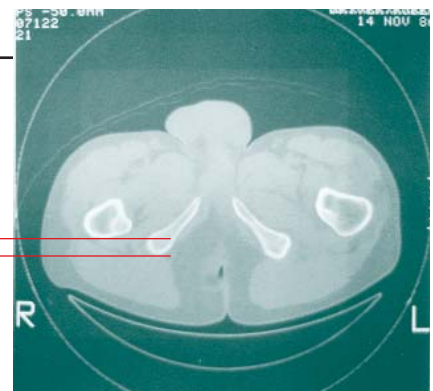

fig 12

Survey Radiograph of adult female CAT SCAN Study of the pelvis and femur.

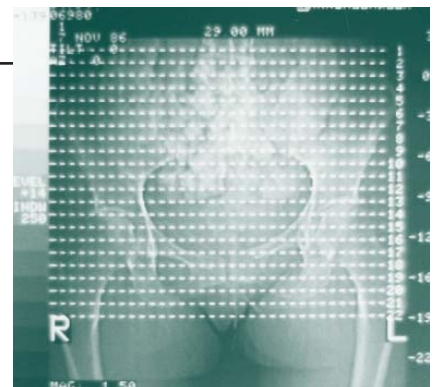
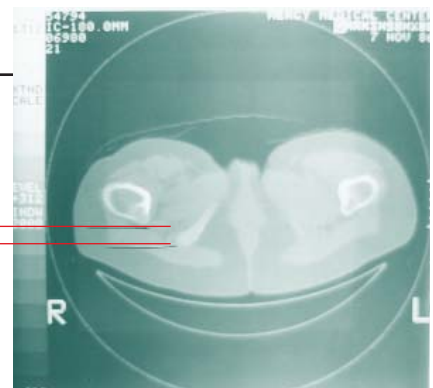

fig 13

Cross Section through Cut #21 of CAT SCAN survey of adult female.

Note: Ischial tuberosity is a medial structure in relation to the shaft of the femur. The ischial tuberosity protrudes at most 1-2cms. below the shaft of the femur.

1-2 cm



(PowerPoint #6, 7)

Section Three:

SEFRS[®] application for splinting femoral fractures

When a patient suffers a fractured femur, the large muscles surrounding the bone react by going into spasm which cause severe pain. Traction splinting prevents further injury and breaks the spasm which eliminates the major source of pain.

Sager Splints: Anatomically engineered to be the best.

fig 14

Note induced malalignment with the Hare Traction Splint.

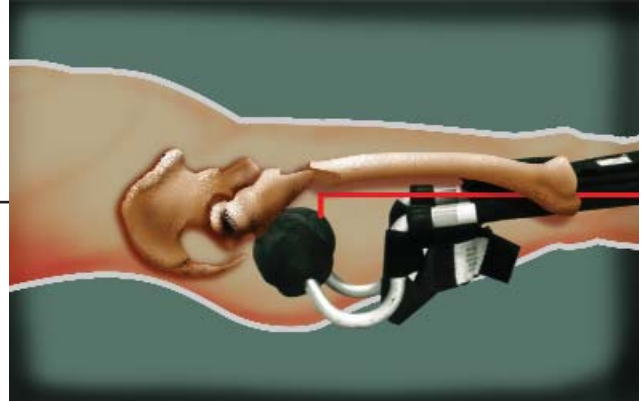
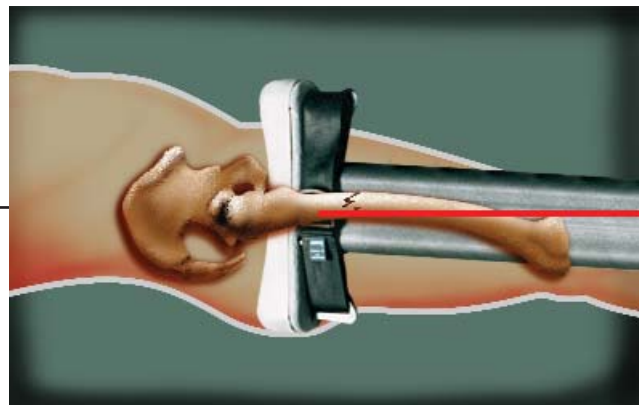

fig 15

Sager Emergency Traction Splints provide near perfect alignment.

(PowerPoint #4)



Quantifiable, Dynamic Traction™ the spring within the Inner Shaft of a SEFRS® splint is dynamic. It continuously reacts to changes in the amount of muscle spasm.

The pain felt by the patient is in part related to the amount of muscle in spasm as well as the degree of spasm. This is why a fractured femur typically results in much more pain than a fractured humerus.

The application of traction upon the muscle tires it and pulls it out of spasm and consequently relieves much of the patient's pain. It also restores the cylindrical shape of the leg and in the process increases tissue pressure within the thigh which inhibits further blood loss. It is interesting to note that blood loss of 1000 – 1500 c.c. is not uncommon with femoral fractures.

The type of traction applied when using **SEFRS**[®] Traction Splints is called "Quantifiable, Dynamic Traction™": "Quantifiable" means that the amount of traction applied is measurable in pounds or kilograms. "Dynamic" means that the amount of traction or "pull" on the fracture site is automatically adjusted in relation to the degree of muscle spasm. Thus, a correct and safe amount of traction is always achieved.

The Spring within the Inner Shaft of a the **SEFRS**[®] splint is dynamic. It continuously reacts to changes in the amount of muscle spasm.

You should notice a DECREASE in the amount of traction registered on the traction scale. As the spasm releases and the leg lengthens, this is normal and desirable, as it acts as a safety mechanism to prevent unnecessarily high amounts of continuous traction being applied. It indicates that the muscle spasm (and patient discomfort) has been reduced.

fig 16

Close-up of traction being applied to a patient.

(PowerPoint #8)



Summary

SEFRS[®] Emergency Traction Splints provide the best mode of traction for field use on fractured femurs. They provide "safe traction" via their specially calibrated stainless steel spring.

SEFRS[®] Splint's also indicate the exact amount of traction force applied and have a dynamic feature that safely varies with the amount of muscle spasm.

Training application sheet #1:

The **SEFRS SX405**[®] Compact Bilateral Traction Splint.



Step 1 ▶ Position

Position the **SEFRS**[™] between the patient's legs, resting the saddle against the ischial tuberosity, with the shortest end of the articulating base towards the ground. In the case of a unilateral fracture, the splint should be placed in the perineum on the side of the injury. In bilateral fractures, excluding pelvic trauma, the side with the greatest degree of injury should be the side of placement. Apply the thigh strap around the upper thigh of the fractured limb. Push the ischial perineal cushion gently down while at the same time pulling the thigh strap laterally under the patient's thigh. This will seat the lower end of the cushion comfortably against the ischial tuberosity. Tighten the thigh strap lightly. Lift the spring clip to extend the inner shaft on the **SEFRS**[™] until the crossbar rests adjacent to the patient's heels.



Step 2 ▶ Set

Note the absence or presence of distal pulses, check for sensation. Position the ankle harness beneath the heel(s) and just above the ankle(s). Fold down the number of comfort cushions needed to engage the ankle above the medial and lateral malleoli. Using the attached hook and loop straps wrap the ankle harness around the ankle to secure snugly. Pull control tabs to engage the ankle harness tightly against the crossbar. Apply Quantifiable Dynamic Traction[™]. Grasp the padded shaft of the **SEFRS**[™] with one hand and the red traction handle with the other; gently extend the inner shaft until the desired amount of traction is recorded on the traction scale. It is suggested to use 10% of the patient's body weight per fractured femur up to 7kg (15 pounds) for each leg. If bilateral fractures are present – the maximum amount would be 14kg (30 pounds). At the hollow of the knees, gently slide the large tensor cravat through and sizer it upwards to the thigh, repeating with the smaller cravats to minimize lower and mid-limb movement.



Step 3 ▶ Secure

Adjust the thigh strap at the upper thigh making sure it is not too tight, but snug and secure, then firmly secure the tensor cravats. Apply the figure 8 strap around the feet to prevent rotation. Note the absence or presence of distal pulses, check for sensation. Patient is now ready for transport.



Warning: All Operators should receive full and proper initial/refresher instruction sessions from a qualified person on detailed use of this equipment and regarding the particular situations in which it should be used.

(PowerPoint #9, 11)

Training application sheet #2: The SEFRS SX405[®] used as a traction splint.

This application has been designed for rapid one person assembly and application when used as a traction splint. Easy to assemble, easy to apply.

The splint can be assembled and applied in under 2.5 minutes. To assemble the splint, simply unfold and secure into place. The SX405[®] has a unique semi-attached design that ensures that no major parts will be lost or incorrectly assembled.



1 Remove and unfold the outer shaft assembly.



2 Remove, unfold and lock the inner shaft assembly.



3 Insert inner shaft assembly into the outer shaft assembly. Splint is ready to apply.

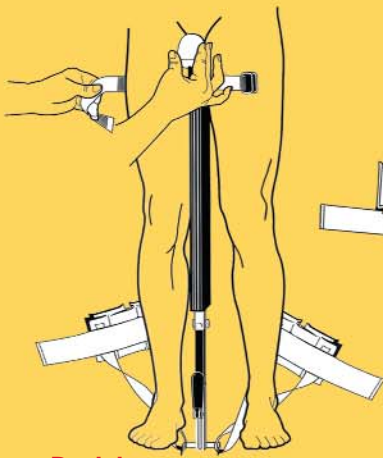

Position:

a Position the Sager SX405[®] between the patient's legs, resting the saddle against the ischial tuberosity, with the shortest end of the articulating base towards the ground.



Set:

b Fold down the number of comfort cushions needed to engage the ankle above the medial and lateral malleoli.



c Using the attached hook and loop straps wrap the ankle harness around the ankle to secure snugly.



d Pull control tabs to engage the ankle harness tightly against the crossbar. Apply **Quantifiable, Dynamic Traction™**. Grasp the padded shaft of the SX405[®] with one hand and the red traction handle with the other; gently extend the inner shaft until the desired amount of traction is recorded on the traction scale.

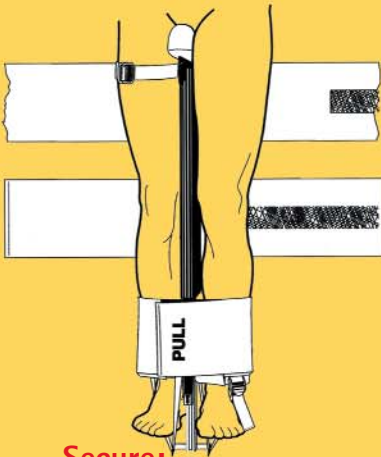

Secure:

e Adjust the thigh straps at the upper thigh making sure it is not too tight, but snug and secure, then firmly secure the tensor cravats.

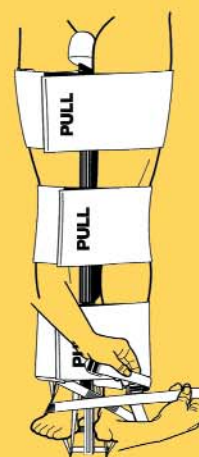
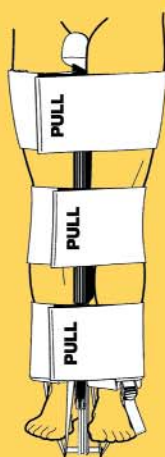

f Apply the figure 8 strap around the feet to prevent rotation. Note the absence or presence of distal pulses, check for sensation. Patient is now ready for transport.

(PowerPoint #9, 11)

Training application sheet #3: The **SEFRS® SX405™** compact bilateral traction splint.

How much traction should I apply?

Apply the amount of traction recommended by your medical consultant, or that required by protocol. For adults, the American Academy of Orthopedic Surgeons recommends gentle traction to a maximum of 7kg (15 pounds) per fractured femur (14kg (30 pounds) for a bilateral fracture). A general rule of thumb is 10% of the patient's body weight per fractured femur. For example; if a patient weighing 45kg (100 pounds) has a single fracture, the appropriate amount of traction would be 4.5kg (10 pounds). If that same person has a bilateral fracture, 9kg (20 pounds) would be estimated. The **SEFRS SX405®** Splint is designed to register a maximum of 14kg (30 pounds) of traction. There are rare circumstances, such as patients who have highly developed muscles, where the initial traction of more than the maximum of 14kg (30 pounds) is required. This is easily accomplished by temporarily extending the splint shaft beyond the 14kg (30 pound) stop, increasing the traction an unknown amount beyond the maximum registered. As the spasm releases the traction force decreases and can be recorded.



Indications and contraindications for the use of traction splints on femoral fractures.

Sager splints are indicated for use on proximal third and mid-shaft femoral fractures.

All traction splints of any kind are contraindicated in the case of fractured pelvises unless the Medical Consultant indicates otherwise, or a MAST Trousers has been applied – in which case a **SX405®** Splint can be applied over the MAST Trousers. Supracondylar fractures of the knee and ankle fractures are also contraindicated. The contraindications listed above are only intended as a basic reference tool. Please defer to federal, state, and/or local protocol for definitive analysis and guidelines.

Articulating Base and Cushion

Articulating Base and Cushion (the saddle) bends laterally for seating and exacting conformance to the ischial tuberosity. With a **SX405®**, most perineal examinations and procedures can be performed with the splint in place – without compromising the comfort and safety of the patient. The **SX405®** has a well-padded shaft cushion which provides additional comfort and stability.



Shock Trousers

If shock trousers are used in cases of multiple trauma, **SX405®** Splints may be used either over or under the shock garment to rapidly provide traction and alignment. The optimum in treatment is to apply the **SX405®** Splint prior to the application of the trousers. In the case where trousers have already been applied, the splint may also be placed over the trousers with good results. If the splint is applied first, the patients' fractured femur is stabilized and it becomes simple to clothe the patient in shock trousers. The shaft of the splint is closely applied to the medial side of the thigh and the ischial perineal cushion is located so that it lies in the perineal opening of the garment. In addition, since the splint is applied closely to the leg, there is excellent contouring of the pressure bladder of the trouser around the shaft of the splint and over the leg. The possibility of tenting between the shock trouser and the splint shaft is so small that it becomes negligible.



Comfort

How comfortable are **SX405®** Splints against male and female genitalia? The ischial perineal cushion of the splint rests against the ischial tuberosity and with natural genital mobility the male genitalia can be checked and moved to ensure it is not under any pressure. During actual accident situations the clothing should be opened, cut and/or removed during the general assessment procedures. In practice trials, loose clothing should be worn to enable genital mobility. (**Note:** the structures used and pressed on are the same as sitting on a bicycle seat).



(PowerPoint #8)



important: To fold Traction Assembly, grasp Traction Tube with thumb against Hinged Tab. Push Hinged Tab, as you would to turn on a flashlight, while gently pulling the solid bar. When solid bar stops, then fold, keeping the bar and tube in alignment.

Attention: Read first – prior to application

Model **SX405** (SEFRS™):

Security Sliding Lock

1. Slide the Security Sliding Lock over hinge of the Inner Shaft and cover the yellow indicator with the red knob.

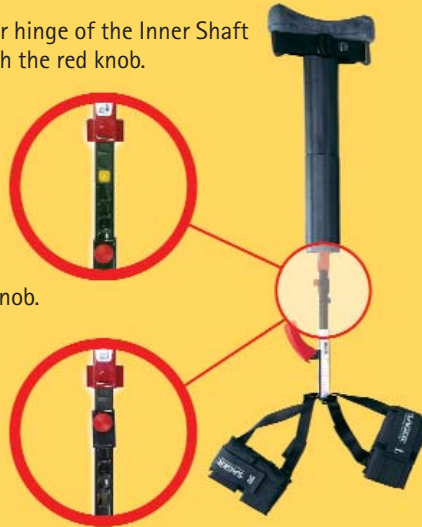

2. Lock down by tightening the red knob.

Important: Follow these additional steps to ensure correct assembly and usage of Sager Extreme Compact Bilateral Traction Splints. Note: the Security Sliding Lock should be applied after traction is applied to the patient and the yellow indicator is visible. On short, light-weight people, the yellow indicator might not be visible if the Traction Bar does not extend out of the Outer Tube. If the Lock is applied before inserting the Traction Bar into the Outer Tube, the range of travel will be limited.

Traction Assembly and Folding Procedure

Diagram 1

Traction Tube

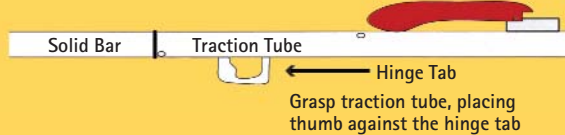
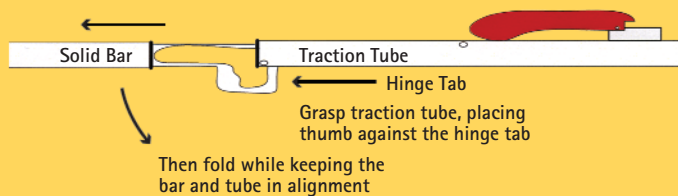

Diagram 2

Traction Tube "pull away from the traction Tube..."



Important: Traction Assembly Packing and Folding Procedure! To refold the inner-traction splint shaft (traction tube) and place in Carrying Case, grasp the traction tube with thumb against Hinge Tab. Push Hinge Tab, as you would to turn on a flashlight, while gently pulling the solid bar. When solid bar stops then fold keeping the bar and tube in alignment.

Warning: Failure to follow Manufacturer's Assembly Instructions and Packing Procedures may result in damage to the splint and/or hinder the application of the splint. Minto Research & Development, Inc. is not responsible for incorrect assembly and/or usage of the splinting device. All Operators should receive full and proper initial/refresher instruction sessions from a qualified person on detailed use of this equipment and regarding the particular situations in which it should be used. Please defer to federal, state, and/or local protocol for definitive analysis and guidelines.

Training application sheet #4: Features and benefits of the SX405[®] Emergency Traction Splint

Feature	Advantage	Benefit
Indicated for treatment in proximal third and mid-shaft femoral fractures.	■ Has a much broader range of application and use than other traction devices.	■ Less equipment to carry
Radio Lucent	■ Radio lucent to all areas of a femoral fracture.	■ Radio lucent design enables Xrays and CATSCANS to be taken without removing the splint.
Compact, robust and light weight	■ Easily stored and carried in most backpacks. Folds into a 14" x 11" x 5" carry case. Hook and loop patches hold each piece of equipment separately and securely.	■ Ensures instant parts identification and access. Enables easy field carry.
Universal: one size fits all (5 th to 99 th percentile of patients).	■ Fits an adult or a child. No delay in application while searching for the right sized splint.	■ One (1) bilateral SEFRS Traction Splint has four (4) times the potential of other splints.
Rapid assembly.	■ The SX405 [®] unfolds and is ready to apply in under 15 seconds.	■ No delay in application while assembling the splint.
Rapid one-person application.	■ Frees other attendants for other patients or procedures. Does not require constant monitoring	■ Less patient manipulation and therefore less pain and discomfort. More time for patient evaluation and care.
Straight in-line traction.	■ Alignment, traction and counter-traction is the same as that provided to patients in operating room theatres undergoing surgical procedures. Sagers' application of traction avoids point pressure on the sciatic nerve and related vascular structures – in the critical proximal third of femoral fractures.	■ Promotes rapid recovery with fewer complications. Sagers splints do not have a half ring posteriorly. This eliminates any pressure on the sciatic nerve and most importantly eliminates the angulation of the fracture site – which occurs with most ischial pad splints.
Stays within the body silhouette.	■ Does not extend beyond the feet of an adult. Eliminates transport complications in helicopters, fixed wing, and van type ambulances.	■ If the patient fits in a stokes basket – the Sager fits!
Quantifiable, Dynamic Traction	■ Designed to continuously show the exact amount of safe, quantifiable traction applied – with no possibility of overtraction. Permits documentation of the traction force applied – a plus for medical legal purposes. The dynamic function permits the traction to decrease automatically and appropriately as the spasm releases.	■ Reduces further trauma and pain. Increased patient comfort. Safe Paramedic use. Continuous overtraction never occurs. Traction is variable – as the spasm decreases, traction decreases. Patients always have the right amount of safe traction.

Section Four:

SEFRS[®] components

The splint proper is manufactured from 303 stainless steel. **SEFRS**[™] Series Articulating Base is comprised of Dupont's Crastin Polyester Resin. The **SEFRS**[™] Cushion is manufactured from Closed Cell CPE (Chlorinated Polyethylene) Foam.

All **SEFRS**[™] units come complete with all components and accessories required for use, including;

The **SX405 SEFRS Sager Emergency Response System** comes complete with all accessories required for use:



- 1 One **SEFRS SX405**[®] Extreme Compact Bilateral Emergency Traction Splint
- 2 One Ischial Perineal Cushion (saddle)
- 3 One Abductor Bridle (thigh strap)
- 4 One Carry Case
- 5 One Pedal Pinion (figure eight strap)
- 6 Two Malleolar Harnesses (ankle harnesses)
- 7 One **SX405 Adaptor**[™]
- 8 Two colour coded **SX405**[®] Extender Shafts
- 9 Two 2"x8" Tensor Cravat
Two 2"x10" Tensor Cravat
Two 2"x18" Tensor Cravat
Two 2"x24" Tensor Cravat
- 10 Two 4"x18" Tensor Cravat
Two 4"x24" Tensor Cravat
- 11 Two 6"x18" Tensor Cravat
One 6"x24" Tensor Cravat
One 6"x32" Tensor Cravat

*Combine cravats to increase length if needed (eg. use a 24" and 32" for full body wrap).

- 12 Red and Black End Caps
- 13 Shoulder Strap/Sling
- 14 Six Security Cravats

SAM[®] **SPLINTS**

- 15 Two 36" C-Curve Sam Splints
- 16 Five Sam Finger Splints

(PowerPoint #9)

⚠ Caution: This product contains Natural Rubber Latex, which may cause allergic reactions.

The splint proper (outer tube assemblies) is manufactured from 303 stainless steel. **SEFRS**[®] Articulating Base is comprised of Dupont's Crastin Polyester Resin. The Shaft Cushion is manufactured from Closed Cell CPE (Chlorinated Polyethylene) Foam. **SEFRS**[®] Cravats are made of "Breath'O'Prene" fabric.

Traction Splint

SEFRS[®] Bilateral Emergency Traction Splint consists of the Ischial Perineal Cushion and Saddle Base (the Articulating base Et cushion), the Outer and Inner Telescoping Shafts, the Cross Bar Harness, Traction Scale and Traction Handle. The Articulating Base and Cushion enables anatomically and physiologically correct countertraction to be applied against the bony structures of the pelvis. These structures include the ischial tuberosity, ischial ramus, pubic ramus, pubic symphysis and mons pubis. These hard points ensure fail safe countertraction – no matter what the patient's position may be! The Articulating Base and Cushion bends laterally for seating and exacting conformance to the ischial tuberosity.

Abductor Bridle

The Abductor Bridle (**thigh strap**) is used to bend and hold the Ischial Perineal Cushion laterally for seating and exacting conformance to the ischial tuberosity.

Malleolar Harness

The Malleolar (**ankle**) Harness is designed to attach around the patient's ankle above the medial and lateral malleoli. The harnesses are marked "Left" and "Right" to indicate the appropriate placement and use.

Pedal Pinion

The Pedal Pinion (**figure eight (8) strap**) is applied around the ankles and feet to prevent internal or external rotation of the distal parts of the fractured bone. It also provides additional splinting.

Tensor Cravat Kit

SEFRS[®] Tensor Cravats are made of "Breath'O'Prene" fabric. The "Breath'O'Prene" fabric wicks away heat and moisture and is form fitting. All of these universal resilient and safety cravats have many other uses; as pressure dressings for road rash, strains, sprains and use as a ligature. Cravats may be combined to increase length as needed (e.g, use a 24" x 32" for a full body wrap). Tensor Cravats may be disposed or cleaned and reused. **SEFRS**[®] also comes with Security Cravats that may be applied to control struggling patients.

Adapter™

SEFRS[®] Adapter™ has a variable range, rotatable from 30 to 330 degrees. The Adapter™ is lightly placed and centered over the fracture site and the arms aligned with each side of the fracture. Note that the arms of the Adapter™ should be parallel to the bone – not the muscle silhouette of the limb. The Adapter™ is locked to retain the fracture configuration, then removed and attached to the padded Splints shafts. **SEFRS**[®] Adapter™ enables splinting of any fracture in position found and features composite plastic construction.

Extender Shafts

SEFRS[®] Extender Shafts feature composite plastic construction. The padded "limb rests" are made from Closed Cell CPE (Chlorinated Polyethylene) foam. They provide additional support and comfort.

Carrying Case

The Carrying Case has been designed to provide easy access, identification and storage of all **SEFRS**[®] components and accessories.

Section Five:

Questions and answers for
the **SEFRS**[®] application
for splinting and treatment
of femoral fractures

Q & A

(PowerPoint #12)

1 What advantage is there to using the **SEFRS SX405**[®] Malleolar (ankle) Harness?

- There is less chance of cutting off circulation with the **SEFRS**[®] Malleolar Harness (ankle harness) because it is applied above the malleoli of the ankle away from the posterior tibial and dorsalis pedis arteries. These arteries are deep in the ankle at the site of application of the **SEFRS**[®] Malleolar Harness.
- The Harness is quick and easy to apply.
- The Harness is now copied and used by almost all splint manufacturers.
- The traditional triple and quadruple type harnesses used with Ischial Pad Traction Splints are applied lower over the foot – directly over the dorsalis pedis and posterior tibial arteries at the location in the foot where they are most superficial and most susceptible to pressure or injuries. These types of harnesses are rarely seen today.

fig 17

Cross section of the ankle above the malleoli at the site of pressure and traction of the Malleolar Harness. Note that the arteries are protected from compression at the malleoli of the ankle.

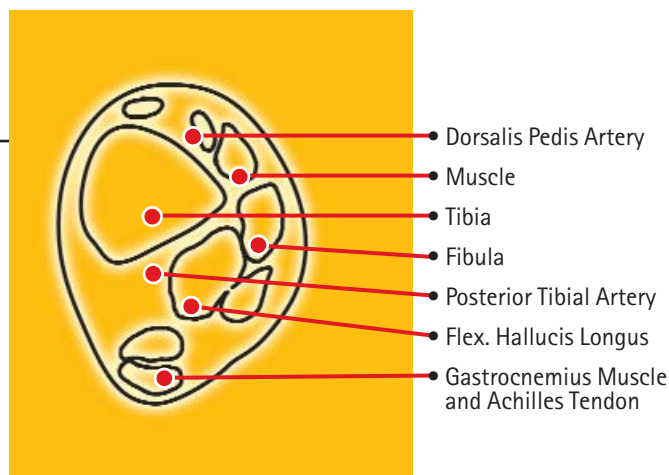
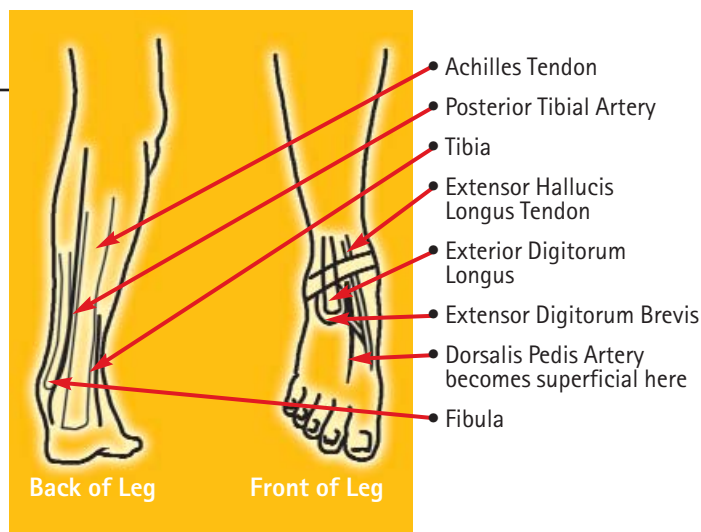

fig 18

Diagram of lower limb. Anterior and posterior view of the lower limb at the site of the Malleolar Harness. Note that at the front of the leg the dorsalis pedis artery is located deep in the anterior ankle and is protected from compression except on the top of the foot. At the back of the leg the posterior tibial artery is protected from compression because it is located between the fibula and achilles tendon.



2 Is there a danger that external rotation of the fractured femur can occur using a **SEFRS**[®] splint?

- No, not when the **SEFRS**[®] splint is properly applied and the Pedal Pinion (figure 8 strap) is used to bind the feet together. External rotation of a fractured femur can and does happen using Ischial Pad Traction Splints that have the foot end raised on a tripod – where the feet cannot be bound together.

3 Is elevation of the foot much better for prevention of leg congestion and swelling?

Any elevation of the injury and the limb distal to it can be helpful – **but look at the facts:**

- Most Ischial Pad Traction Splints in use today elevate the foot seven (7) inches. The hip may not be elevated at all – or at most – be elevated one (1) to two (2) inches.
- If the foot is the injured part, there may be some improvement in drainage and a decrease in congestion and swelling **of that foot**. However, this does nothing for the drainage of the injured femur, or the limb distal to it.
- In order to take advantage of elevation, one would have to raise the foot (ankle) approximately twenty-two (22) inches in order to raise the femoral injury above the level of the heart. **However, even this extreme elevation will not raise the injury above the level of the patient's heart when the fracture is at the proximal end of the femur.**
- Ischial Pad Traction Splints cannot raise femurs above the level of the heart therefore; this minimal elevation is of no value. It can also be detrimental.
- If elevation of the fracture site is desired, trendellenberg positioning of the patient should be considered. This is the only method to truly elevate the femur above the level of the patient's heart.

One cannot bind the feet together unless the good leg is raised also!

fig 19

This minimal elevation is of no value.

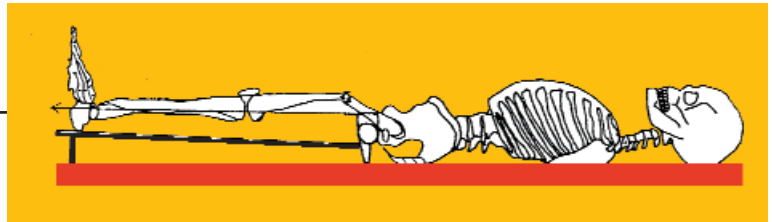
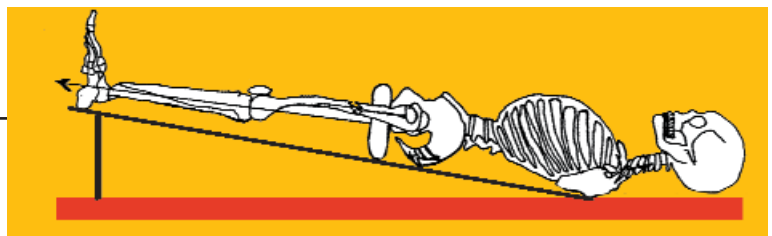

fig 20

If elevation of the fracture site is desired, Trendellenberg positioning of the patient is the more appropriate course of action.



4 Are SEFRS[®] splints contraindicated in the case of massive fractures of the pelvis?

- Yes, but so are all traction splints – including Ischial Pad Traction Splints since they also can compress and deform the ischial tuberosity which is part of the pelvis and subject to movement.

5 Why should I purchase a SEFRS[®] Splint when some hospitals in my area utilize Ischial Pad Traction Splints and can exchange splint for splint?

SEFRS[®] splints are the most advanced anatomically engineered splints sold on the world market today. **Remember:**

- The **SEFRS[®]** splint is the only splint that provides bilateral splinting capabilities and Quantifiable Dynamic Traction™. One splint can treat either an adult or child with one or two fractured femurs. Ischial Pad Traction Splints require the purchase of four splints to have the range of use of one **SEFRS[®]** splint. Moreover, you will always know how much traction you have applied!
- Solution! Have your hospital join the increasing number of progressive hospitals nationwide who use **SEFRS[®]** Splints exclusively for in-hospital and service exchange use!

6 Are SEFRS[®] traction splints comfortable to wear? Do they press against male and female genitalia?

To date, no significant complaint of discomfort due to pressure from the Perineal Cushion has been recorded. When patients do complain, there has always been some aspect of the application technique of the splint that has been overlooked. **Remember:**

- Trials using a **SEFRS[®]** splint in practice situations should be undertaken with the “patient” wearing loose shorts and jeans so that natural genital mobility can take place. This is important for both male and female trainees/candidates.
- In real life situations, clothing of course, should be opened, cut, and/or removed as part of the evaluation process of the patient.
- The Ischial Perineal Cushion should be placed snugly in the lateral perineal area against the thigh and the ischial tuberosity and then strapped into place before applying traction.

fig 21

Few people, male or female, complain about discomfort when sitting or riding on a bicycle. The structures used and pressed on in this situation are the same as those used when wearing a **SEFRS[®]** splint).

Ischial Pad and Half Ring Splints require the purchase of four splints to have the range of use of one **SEFRS[®]** Traction Splint.



7 What advantage is there to using a *SEFRS*[®] splint with anti-shock trousers? Note: anti-shock trousers are in much less use today.

SEFRS[®] splints are so versatile that anti-shock trousers can be applied over the leg of a patient wearing a *SEFRS*[®] splint just as easily – probably easier – than on a patient not wearing a splint at all. After the splint is applied, the patient's fractured femur is stabilized, and it becomes easy to clothe a patient in an anti-shock garment. **Remember:**

- The shaft of the splint is closely applied to the medial side of the thigh and the Ischial Perineal Cushion is located so that it lies in the perineal opening of the anti-shock garment.
- Since the splint is closely applied to the leg, there is excellent contouring of the pressure bladder of the trouser around the shaft of the splint and over the leg. The possibility of tenting between the shock trouser and the splint shaft is so small that it becomes negligible.
- Ischial Pad Traction Splints are irregular in shape and poorly conform to the shape of a patient's leg when anti-shock trousers are applied.

fig 22

SEFRS **SX405**[®] splints mate perfectly with anti-shock trousers – inside and out!



fig 23

If the patient fits inside a helicopter – the *SEFRS* **SX405**[®] fits.



8 SEFRS[®] splints provide medial splinting and traction as well as prevention of internal and external rotation. Is this less desirable than posterior splinting?

No, not at all. One might consider posterior splinting as most desirable if one was transporting a patient without the use of a basket, spine board, and/or stretcher. This never happens, so why provide posterior support on a device that requires posterior support to be effective? **Remember:**

- Ischial Pad Traction Splints must have a firm support beneath them in order to work and not slip off the ischial tuberosity. Example: It is difficult to apply these devices in snow.
- Time motion studies clearly reveal; an economy of time, decrease of unnecessary steps, decreased movement of the patient, and, a decrease in morbidity moving the patient from the place of injury to the hospital when a Sager Splint is used.
- Immobilization is better using a **SEFRS[®]** splint if the patient has a proximal fracture of the femur – which is the most common type of femoral fracture.
- **SEFRS[®]** splinting system works well with a spine-board or stretcher.
- **SEFRS[®]** splints also work well with the Minto Breakaway Flat. The Minto Breakaway Flat have been uniquely designed to complement the wide range of patient sizes.

9 Other splints utilize the outside (lateral side) of the leg. Can SEFRS[®] Splints be placed and utilized on the outside of the leg?

SEFRS[®] Splints were designed to be used in the same manner as that used in orthopedic operating theatres when open reduction and splinting is needed to treat a fractured femur. The splint is placed against the ischial tuberosity medial to the shaft of the femur. This avoids point pressure on the sciatic nerve as well as other vascular and soft tissue structures. It also provides the safest mode for reduction of the fracture.

Lateral placed splints utilize a sling. Among other concerns, with the use of a sling there is no direct point of countertraction against the ischial tuberosity medial to the shaft of the femur. A direct point of countertraction creates optimum alignment of the fracture.

fig 24

Minto Breakaway Flat model B101.



Indications: SX405® splints are indicated for use on proximal third and mid-shaft femoral fractures.

Contraindications for the use of traction splints for femoral fractures.

A fracture of the pelvis occurring with a fracture of the femur is generally a contraindication for the use of a traction splint of any type. A **SEFRS®** Emergency Traction Splint is not contraindicated when MAST Trousers are used to immobilize the fractured pelvis. In this situation, **SEFRS®** splints may be applied over MAST Trousers if treatment of the fractured femur is indicated or desired. **SEFRS®** traction is quantifiable and gentle and will not disrupt or move pelvic bones immobilized by MAST Trousers.

Supracondylar fractures of the distal end of the femur are contraindicated because traction can cause anterior rotation of the distal bone fragment – forcing the sharp fractured bone end down into the popliteal artery and nerve. These fractures should be splinted as found.

Compound fractures of the femur with bone fragments sticking through the skin may be a contraindication. Guidelines by local protocol or instructions by a Medical Consultant should be followed.

Fractures of the ankle and foot are also contraindicated. Pressure from the ankle harness and from traction is not therapeutic.

The indications and contraindications listed above are only intended as a basic reference tool. Please defer to federal, state, and/or local protocol for definitive analysis and guidelines.

Warning: All operators should receive full and proper initial and refresher instruction sessions from a qualified person on detailed use of this equipment and regarding the particular situations in which it should be used.

 **Security Cravats:** NOTICE TO ALL SEFRS USERS. There is a small subset of patients who may be agitated or struggling and uncooperative due to drug use or brain injury. **These cravats can be used in special circumstances for tactical medical rescue situations.**

In the normal course of splinting a patient, first apply the regular stretchable cravats to secure the limb. **If there is a need to totally prevent any incidental movement due to extrication from a wreckage or struggling by the patient, apply the (non-stretchable) Security Cravats over the regular cravats to completely immobilize the patient.**

NOTE: It is vitally important to monitor patient circulation and sensation when Security Cravats are in place. There is a danger that these cravats can create a tourniquet effect and should be removed as early as possible or be loosened and tightened consistent with good blood circulation if there is a continuing need.

Cleaning Instructions:

Software Goods, Stainless Steel and **Adaptor™**: “Manu-Klenz”¹ (i.e.: Sodium Dodecylbenzene Sulfonate and Coconut Diethylthanolamide). Effective manual washing of heavily soiled washable surfaces, medical instruments, counters, glass and plastic surfaces.

Directions: 1 ounce Manu-Klenz to 1 gallon water.

Stainless Steel: 70% Alcohol solution or above instructions.

Foam Rubber, Shaft

and Extender Pad: “Precise”² Hospital Foam Cleanser/Disinfectant. (1, 2 or other comparable product).

Adaptor™: DO NOT DISASSEMBLE ADAPTOR TO CLEAN! Immerse in cleaning solution. Let drip dry or blow dry with high pressure.

 **Caution:** Sager Emergency Traction Splints are just that – short-term emergency traction devices for use at the scene of an accident and while transporting the patient for more definitive care. Prolonged use of any traction device can cause pressure sores and/or other medical problems. If prolonged use is unavoidable, the splint contact areas should be monitored frequently and reduced traction and/or no traction and/or repositioning of the device should be considered. Please refer to local/state/federal splinting protocols for definitive guidance.

Section Six:

Student examinations (i) Femoral Traction Splint

Practical examination for use by **SEFRS SX405**[®] Emergency Traction Splints students. Includes test paper, student exercise and a certificate for successful candidates.

Practical Examination (i)

SEFRS[®] Emergency Traction Splints

Name: _____

Student i.d. #: _____

Date: _____

Course: _____

Questions 1 - 23, 2 points each.

- 1 If elevation of a femur fracture is desired, the only method to truly elevate the femur above the level of the heart is:
 - a Use an ischial pad traction splint with tripod.
 - b Trendelenberg positioning of the patient.
 - c Position patient on spine board with head elevated.
 - d Place patient in side position with fracture site up.

- 2 What is the best method of preventing external rotation of a fractured femur?
 - a Apply an ischial pad splint with tripod which binds the foot of the injured limb.
 - b Bind the feet together on the transport stretcher.
 - c Properly apply a Sager Splint which utilizes a Pedal Pinion (figure 8) strap to bind the feet together.
 - d Immobilize patient on Ked board.

- 3 **SEFRS**[®] Emergency Traction Splints feature "Quantifiable, Dynamic Traction[™]". Among other things, this feature enables first responders to:
 - a Measure traction in pounds or kilograms.
 - b Document the traction force applied.
 - c Reduce the risk of continuous overtraction.
 - d All of the above.

4 You have a 6'6" tall patient with a fractured femur needing transport in a Stokes basket. Which of the following features and benefits are most critical to the patient? Choose only one:

- a A revolutionary manual ratchet traction mechanism.
- b Straight in-line traction.
- c Quantifiable, Dynamic Traction™ (traction handle and scale).
- d A handy tripod.
- e Both unilateral and bilateral splinting capabilities.
- f Exclusive unilateral splinting capabilities only.
- g Articulating Base and Cushion.
- h Containment within the body silhouette™

5 The advantages and benefits of a single rescuer being able to apply a **SEFRS**[®] splint are:

- a Frees second attendant for other patients and procedures.
- b Less patient manipulation and therefore less pain and discomfort.
- c More time for patient evaluation and care.
- d Does not require constant monitoring and adjustments.
- e All of the above.

6 When a **SEFRS**[®] splint is properly applied, the structures used and pressed on are the same as those:

- a Used and pressed on when riding a stationary bicycle.
- b Used and pressed on when riding a unicycle.
- c Used and pressed on when riding a mountain bike.
- d Used and pressed on when straddling a fence.
- e All of the above.

7 The purpose of elasticized Tensor Cravats is to:

- a Splint the leg.
- b Further immobilize the leg.
- c Help decrease the blood loss at the fracture site.
- d All of the above.

- 8 In the case of massive fractures of the pelvis, which type of traction splints are contraindicated?
- a **SEFRS**[®] Emergency Traction Splints
 - b Hare Traction Splints
 - c Donway Traction Splints.
 - d Ferno Traction Splints.
 - e Reel Traction Splints.
 - f All of the above.
- 9 The ischial tuberosity is a structure that is _____ to the shaft of the femur:
- a Superior
 - b Inferior
 - c Medial
 - d Lateral
- 10 Cat Scan studies reveal that the ischial tuberosity protrudes a maximum of _____ cms. below the level of the shaft of the femur:
- a 10 - 12 cms.
 - b 6 - 8 cms.
 - c 4 - 6 cms.
 - d 1 - 2 cms.
- 11 In the intact human limb a positive tissue pressure is established because the fascia (muscle sheath) forms a _____ which maintains its shape due to the internal support of the femoral bone:
- a Circle.
 - b Cylinder.
 - c Ellipse.

- 12 The most important action of applying traction to a fractured femur in a patient who is hypovolemic and/or is developing shock from multiple injuries is:
- a Align the fragments.
 - b Pain relief.
 - c Prevent damage to nerve and vascular structures
 - d Minimize blood loss.
- 13 The various modes for traction can be divided into three broad groups. Which is the safest for prehospital care?
- a Continuous traction (weight and pulley).
 - b Static traction (drum and crank).
 - c Dynamic traction (spring traction).
- 14 Manual traction by a first responder or paramedic falls in the category of dynamic traction. It has one serious drawback as well as one serious limitation. These are:
- a The drawback of unknown traction.
 - b The limitation of human endurance.
 - c Increased force with time.
 - d Over-extension occurs.
 - e Forces decrease with time.
 - f C and D
 - g A and B
 - h A and E
 - i A and D
- 15 The **SEFRS**[®] Articulating Base and Cushion functions in the same manner as a:
- a Hare Splint.
 - b Reel Splint
 - c Thomas Full Ring or true Half Ring
 - d All of the above.

- 16 The **SEFRS**[®] Articulating Base and Cushion bends laterally for seating and exacting conformance to the:
- a Inner thigh.
 - b Ischial tuberosity.
 - c Symphysis pubis
 - d Groin.
- 17 The American Academy of Orthopedic Surgeons recommends gentle traction to a maximum of _____ per fractured femur on an adult patient which is:
- a 15 pounds per leg.
 - b 30 pounds per leg.
 - c 15 kilograms per leg.
 - d You pull traction until the patient gets relief.
- 18 **SEFRS**[®] dynamic function enables the traction to _____ as the spasm releases:
- a Maintain.
 - b Decrease.
 - c Increase.
- 19 **SEFRS**[®] splint traction will fit a patient ranging in age from a _____:
- a A 6 year old to an adult over 7 feet in height.
 - b A 3 year old to an adult over 7 feet in height.
 - c A 4 year old to an adult over 6 feet in height.
 - d A 4 year old to an adult over 7 feet in height.
- 20 **SEFRS**[®] traction splints are indicated for _____ percent of femoral fractures:
- a 100
 - b 75
 - c 93
 - d 9

- 21 Ischial Pad traction splints are indicated for _____ percent of femoral fractures:
- a 75
 - b 93
 - c about 78
 - d About 9
- 22 Bleeding to some degree is a common problem with fractured femurs. The average amount of blood loss is:
- a 1000 c.c.
 - b 1500 c.c.
 - c 3000 c.c.
 - d 1500 - 3000 c.c.
- 23 The amount of pain felt by a patient with a fractured femur is in part related to the amount of _____:
- a Amount of blood loss.
 - b Degree of Angulation.
 - c Anesthesia of the part.
 - d Amount of spasm.
- 24 The **SEFRS**[®] Infant Bilateral Emergency Traction Splint has been designed to reduce the risk of _____:
- a Over traction.
 - b Knee edema.
 - c Injury to epiphyseal growth centers.
 - d All of the above.
- 25 How long can a **SEFRS**[®] Emergency Traction Splint be left on?
- a **SEFRS**[®] Emergency Traction Splints are just that – a device for emergency traction and transportation of patients with fractured femurs from the point of injury to the hospital. They should be removed when the patient is in the care of attending hospital personnel.
 - b **SEFRS**[®] Emergency Traction Splints can be left on as long as the patient doesn't complain.
 - c **SEFRS**[®] Emergency Traction Splints can be left on for as long as 24 hours.

Practical examination (i): Answer key

SEFRS SX405[®] Traction Splints

- 1 If elevation of the femur fracture is desired, the only method to truly elevate the femur above the level of the heart is: **(b) Trendelenberg positioning of the patient.**
- 2 What is the best method of preventing external rotation of a fractured femur?
(c) Properly apply a SEFRS[®] splint which utilizes a Pedal Pinion (figure 8) strap to bind the feet together.
- 3 SEFRS[®] traction splint features "Quantifiable, Dynamic Traction™". Among other things, this feature enables first responders to: **(d) All of the above.**
- 4 You have a 6'6" tall patient with a fractured femur needing transport in a Stokes basket. Which of the following features and benefits are most critical to the patient? Choose only one. **(h) Containment within the body silhouette™.**
- 5 The advantages and benefits of a single rescuer being able to apply a SEFRS[®] splint are: **(e) All of the above.**
- 6 When a SEFRS[®] splint is properly applied, the structures used and pressed on are the same as those: **(e) All of the above.**
- 7 The purpose of elasticized Tensor Cravats is to: **(d) All of the above.**
- 8 In the case of massive fractures of the pelvis, which type of traction splints are contraindicated? **(f) All of the above.**
- 9 The ischial tuberosity is a structure that is _____ to the shaft of the femur.
(c) Medial.
- 10 Cat Scan studies reveal that the ischial tuberosity protrudes a maximum of _____ cms. below the level of the shaft of the femur. **(d) 1–2 cms.**
- 11 In the intact human limb a positive tissue pressure is established because the fascia (muscle sheath) forms a _____ which maintains its shape due to the internal support of the femoral bone. **(b) Cylinder.**
- 12 The most important action of applying traction to a fractured femur in a patient who is hypovolemic and/or is developing shock from multiple injuries is:
(d) Minimize blood loss.

- 13** The various modes for traction can be divided into three broad groups. Which is the safest for prehospital care? **(c) Dynamic traction (spring traction).**
- 14** Manual traction by a first responder or paramedic falls in the category of dynamic traction. It has one serious drawback as well as one serious limitation. These are:
(g) – (a) and (b).
- 15** The **SEFRS**[®] articulating base and cushion functions in the same manner as a:
(c) Thomas Full Ring or true Half Ring.
- 16** The **SEFRS**[®] Articulating Base and Cushion bends laterally for seating and exacting conformance to the: **(b) ischial tuberosity.**
- 17** The American Academy of Orthopedic Surgeons recommends gentle traction to a maximum of _____ per fractured femur on an adult patient which is:
(a) 15 pounds per leg.
- 18** **SEFRS**[®] dynamic function enables the traction to _____ as the spasm releases.
(b) Decrease.
- 19** The **SEFRS**[®] splints will fit a patient ranging in age from a _____.
(d) A 4 year old to an adult over 7 feet in height.
- 20** **SEFRS**[®] traction splints are indicated for _____ percent of femoral fractures.
(c) 93.
- 21** Ischial Pad traction splints are indicated for _____ percent of femoral fractures:
(d) About 9.
- 22** Bleeding is a common problem with fractured femurs. The average amount of blood loss is: **(b) 1500 c.c.**
- 23** The amount of pain felt by a patient with a fractured femur is in part related to the amount of: **(d) Amount of spasm.**
- 24** The **SEFRS**[®] Infant Bilateral Emergency Traction Splint has been designed to reduce the risk of: **(d) All of the above.**
- 25** How long can a **SEFRS**[®] Emergency Traction Splint be left on? **(a) SEFRS**[®] Emergency Traction Splints are just that – a device for emergency traction and transportation of patients with fractured femurs from the point of injury to the hospital. They should be removed when the patient is in the care of attending hospital personnel.

Student Exercise SEFRS® Parts Identification.
Place the correct number by the part:

- 1 One **SEFRS SX405®** Extreme Compact Bilateral Emergency Traction Splint
- 2 One Ischial Perineal Cushion (saddle)
- 3 One Abductor Bridle (thigh strap)
- 4 One Carry Case
- 5 One Pedal Pinion (figure eight strap)
- 6 Two Malleolar Harnesses (ankle harnesses)
- 7 One **SX405 Adaptor™**
- 8 Two colour coded **SX405®** Extender Shafts
- 9 Two 2"x8" Tensor Cravat
Two 2"x10" Tensor Cravat
Two 2"x18" Tensor Cravat
Two 2"x24" Tensor Cravat
- 10 Two 4"x18" Tensor Cravat
Two 4"x24" Tensor Cravat
Two 6"x18" Tensor Cravat
- 11 One 6"x24" Tensor Cravat
One 6"x32" Tensor Cravat

*Combine cravats to increase length if needed (eg. use a 24" and 32" for full body wrap).

- 12 Red and Black End Caps
- 13 Shoulder Strap/Sling
- 14 Six Security Cravats

SAM® SPLINTS

- 15 Two 36" C-Curve Sam Splints
- 16 Five Sam Finger Splints



Student Exercise SEFRS[®] Parts Identification.
Answer key:

- 1 One **SEFRS SX405**[®] Extreme Compact Bilateral Emergency Traction Splint
- 2 One Ischial Perineal Cushion (saddle)
- 3 One Abductor Bridle (thigh strap)
- 4 One Carry Case
- 5 One Pedal Pinion (figure eight strap)
- 6 Two Malleolar Harnesses (ankle harnesses)
- 7 One **SX405 Adaptor**[™]
- 8 Two colour coded **SX405**[®] Extender Shafts
- 9 Two 2"x8" Tensor Cravat
Two 2"x10" Tensor Cravat
Two 2"x18" Tensor Cravat
Two 2"x24" Tensor Cravat
- 10 Two 4"x18" Tensor Cravat
Two 4"x24" Tensor Cravat
Two 6"x18" Tensor Cravat
- 11 One 6"x24" Tensor Cravat
One 6"x32" Tensor Cravat

*Combine cravats to increase length if needed (eg. use a 24" and 32" for full body wrap).

- 12 Red and Black End Caps
- 13 Shoulder Strap/Sling
- 14 Six Security Cravats

SAM[®] SPLINTS

- 15 Two 36" C-Curve Sam Splints
- 16 Five Sam Finger Splints

(PowerPoint #9)



Section Seven:

SX405 Adaptor[™] for the treatment of all body fractures

The **SX405 Adaptor**[™] has been designed for rapid assembly and rapid application. The unit can be assembled and applied in under 60 seconds. To assemble the unit, simply follow the easy steps illustrated on the following pages.

(PowerPoint #13, 24)

Training application sheet #1:

The **SX405 Adaptor**[™] Sager Emergency Fracture Response System.

The **SEFRS Adaptor**[™] has been designed for rapid assembly and rapid application. The unit can be assembled and applied in under 60 seconds. To assemble the unit, simply follow the easy steps illustrated on the following pages. The **SX405**[®] has been designed to treat any fracture in the position found without patient movement or pain.

Packing sequence:

Note easy visualization of the various sized cravats which are firmly secured to both sides of the hinged panel. Lift the hinged panel to access compact Sager, **SAM**[®] **SPLINTS** and Extender Shafts.

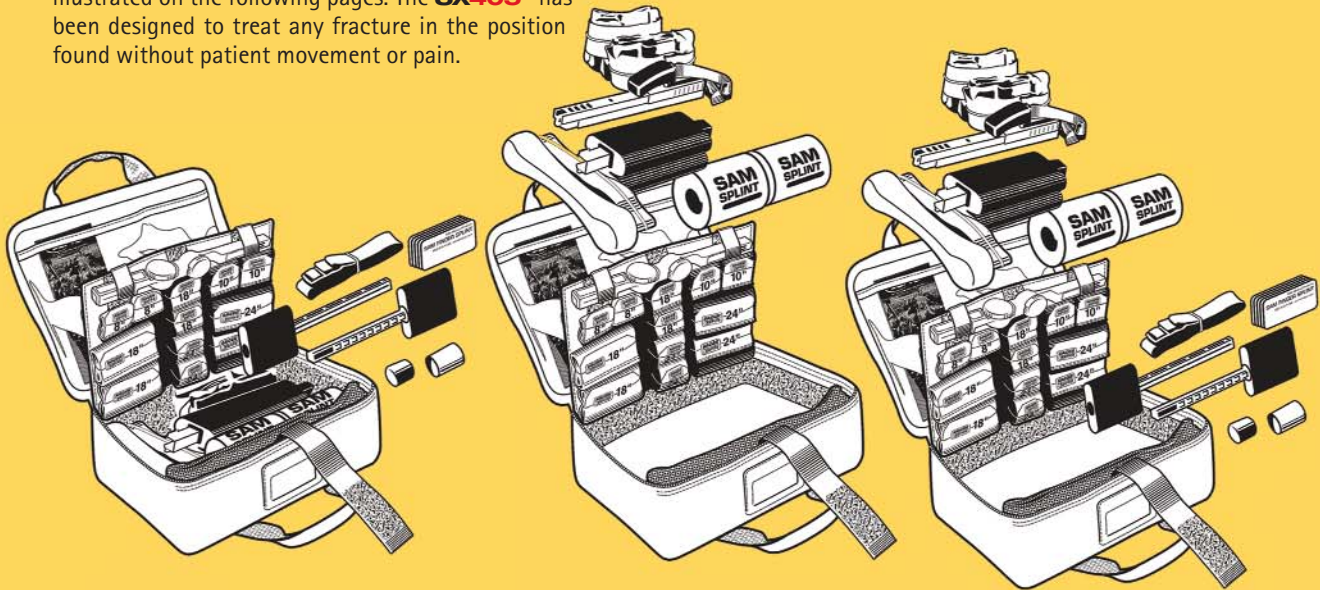

Initial steps and index of parts:

Note: Press button latch and remove the Ischial Perineal Cushion. Then insert the **SX405**[®] **Adaptor**[™]

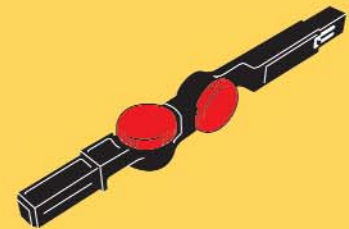

● Variable range **Adaptor**[™] rotatable from 30 to 330 degrees

● With extenders in place with the **Adaptor**[™]. The lengths noted will splint the 95th percentile of patients.

● Soft closed cell foam pad on outer shaft, will not absorb fluids.

● Colour coded extender with foam pad.

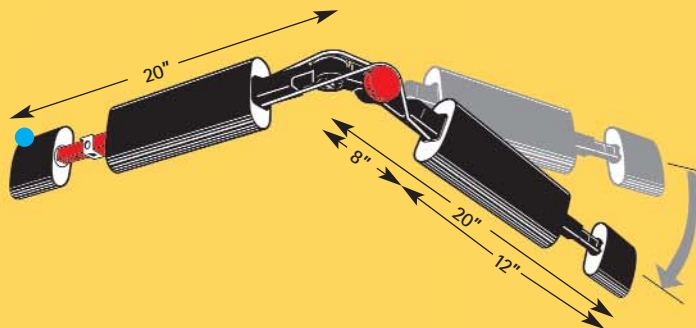

(PowerPoint #13, 14)

Training application sheet #2:

The **SX405™ SEFRS® Adaptor™** Sager Emergency Fracture Response System.

SEFRS[®] unique design ensures virtually pain-free application. The **Adaptor™** is lightly placed and centered over the fracture site and the arms aligned with each side of the fracture. Make sure that the arms of the **Adaptor™** are parallel to the bone – not the muscle silhouette of the limb. The **Adaptor™** is locked to retain

the fracture configuration, then attached to the padded splint shafts. **SEFRS**[®] is an excellent device for extrication. When the splint is in place it remains within the silhouette of the injured limb; no extraneous parts to hang-up or impede when extricating patient.

(PowerPoint #15, 16)

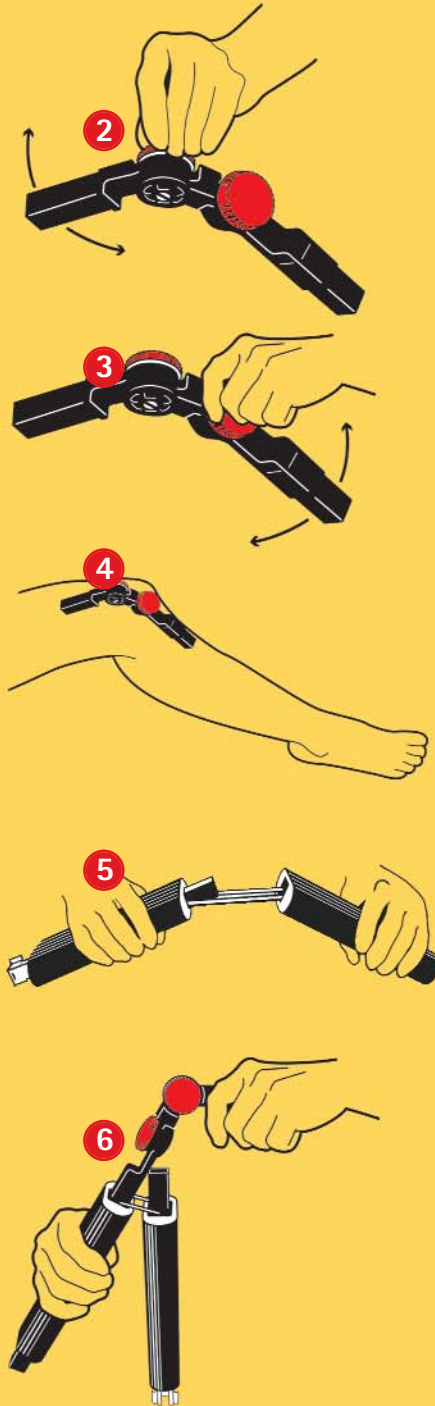

Treatment of all other fractures without traction. Fractures can be splinted in the position found.

Turn each of the red **Adaptor™** knobs counter-clockwise to unlock each of the rotatable arms.

2 Unlock this knob. Range of **vertical** motion; 30° to 330°.

3 Unlock this knob. Range of **lateral** motion; 30° to 330°.

note: One (1) full 360° rotation/turn of the knob is sufficient to make any adjustment you need.

4 Place the loose and malleable **Adaptor™** on the fracture as shown. Make sure the arms of the device lay parallel, centered and in-line with the arms of the proximal and distal parts of the fractured limb. Lock the **Adaptor™** arms by turning the knobs clockwise. Make sure teeth are aligned, then tighten.

5 Separate the two halves of the outer shaft as shown.

6 Insert the long arm of the **Adaptor™** into the large hole in the outer shaft as shown.

7 Always insert the yellow marked short arm of the **Adaptor™** into the colour coded yellow marked outer shaft as shown.

8 Hook the bungy cords over the knobs to move them out of the way.

9 Splint is now ready to apply to the fracture.

10 Depending on patient size, add Extender Shafts to extend the length of the splint: **red to red, black to black**, then place prepared splint on fractured limb.

11 Apply tensor cravats as shown. Patient is now ready for extrication and transport.

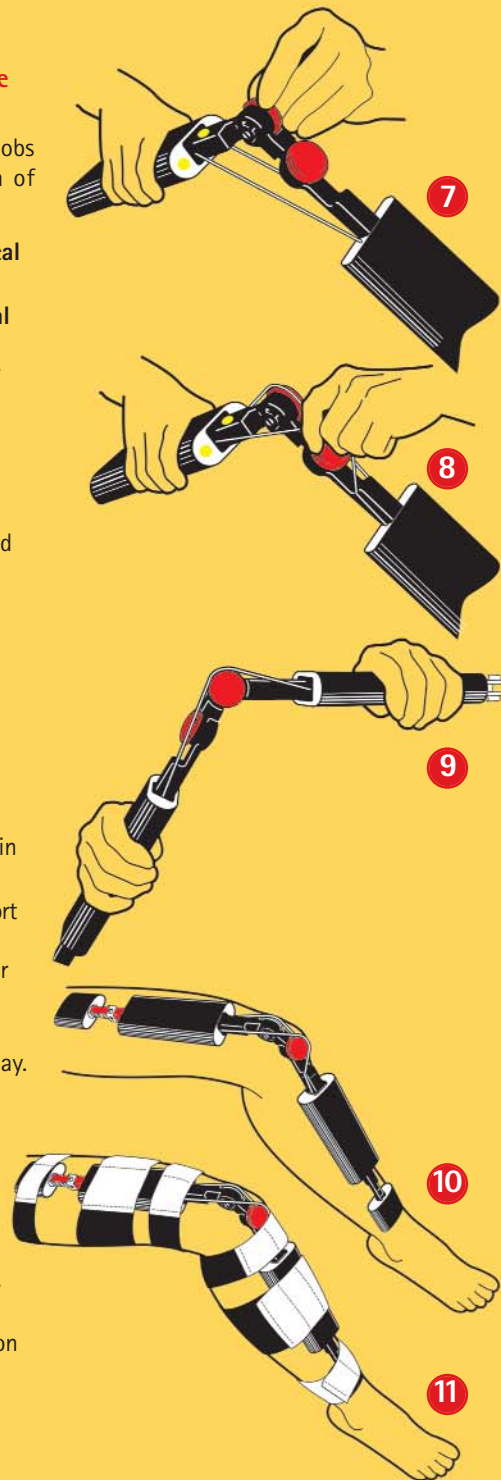

Training application sheet #3. Lower limbs:

The **SX405 Adaptor**[™] Sager Emergency Fracture Response System.

Extraction Procedure

- 1 After clearing obstruction with Jaws of Life; position the splint in preparation for extraction splinting of limb in position found.
- 2 If ankle is unstable, **SAM**[®] **SPLINTS** can be used to immobilize with figure-of-eight strap.



SAM[®] **SPLINTS:**

- A** (The C-Curve): Curve the **SAM**[®] **SPLINT** length-wise to create a longitudinal bend which gives the splint strength.
- B** (The Reverse C-Curve); Curve the outside edges in the opposite direction to make it even stronger.
- C** (The T-Curve): Double the **SAM**[®] **SPLINT** or create a T-Bend for extra strength.

(PowerPoint # 17, 18, 19)

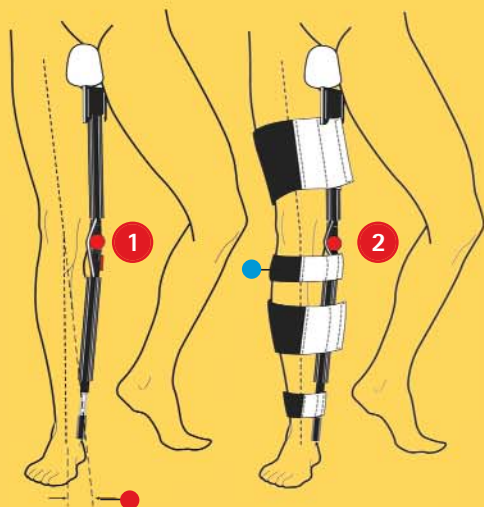
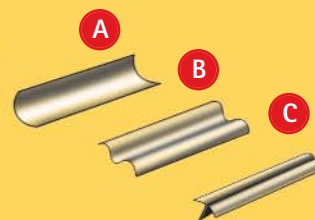

Straight Leg Knee Injury

- 1 When splinting with Sager Emergency Fracture Response System (**SEFRS**[®]) create a 6-10 degree valgus and lock into place on the distal half of the Splint.
- 2 This Tensor Cravat should be added.
 - distal to the head of the fibula
 - Normal 6-degrees valgus of the tibia/fibula at the knee joint

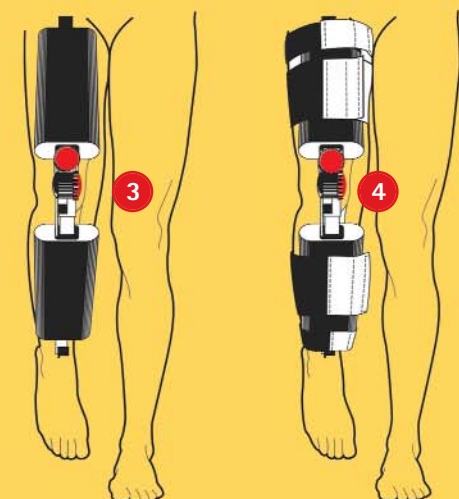

Bent Knee Injury

- 3 Anterior position of Splint for bent knee injuries.
- 4 Place Tensor Cravats as shown. Knee immobilized.

! A Traction splint is contraindicated in any knee injury. Proper leg splinting: Injuries at the knee should be splinted in position found. Attempt to straighten a bent knee is only indicated if pulses are absent and leg straightening is possible without pain or resistance to movement.

Training application sheet #4. Lower limbs:

The **SX405 Adaptor**[™] Sager Emergency Fracture Response System.

Fracture dislocation of the knee

5 Splint position for fracture dislocation knee injury.

6 Place Tensor Cravats as shown. Knee immobilized.

7 Alternate splint placement.

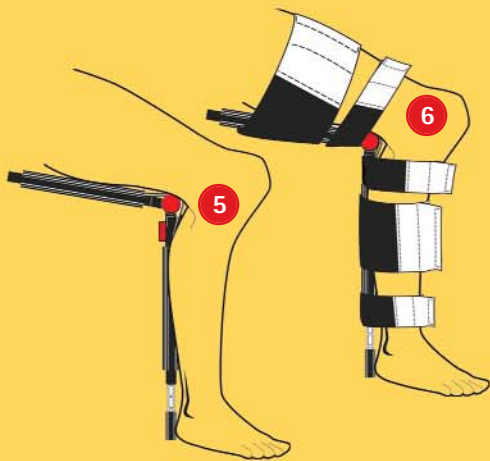

Ankle Injury

8 Splint position for ankle injury.

9 Place Tensor Cravats as shown. Ankle immobilized.

(PowerPoint #20, 21)

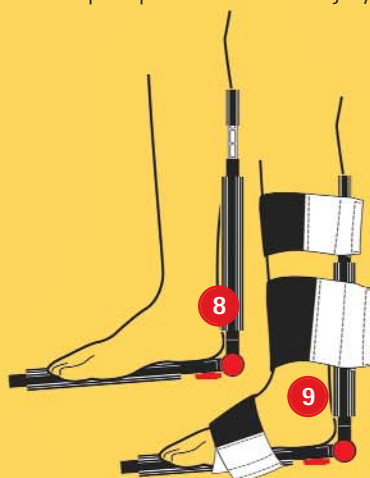

Training application sheet #5. Upper limbs:

The **SX405 Adaptor**[™] Sager Emergency Fracture Response System.

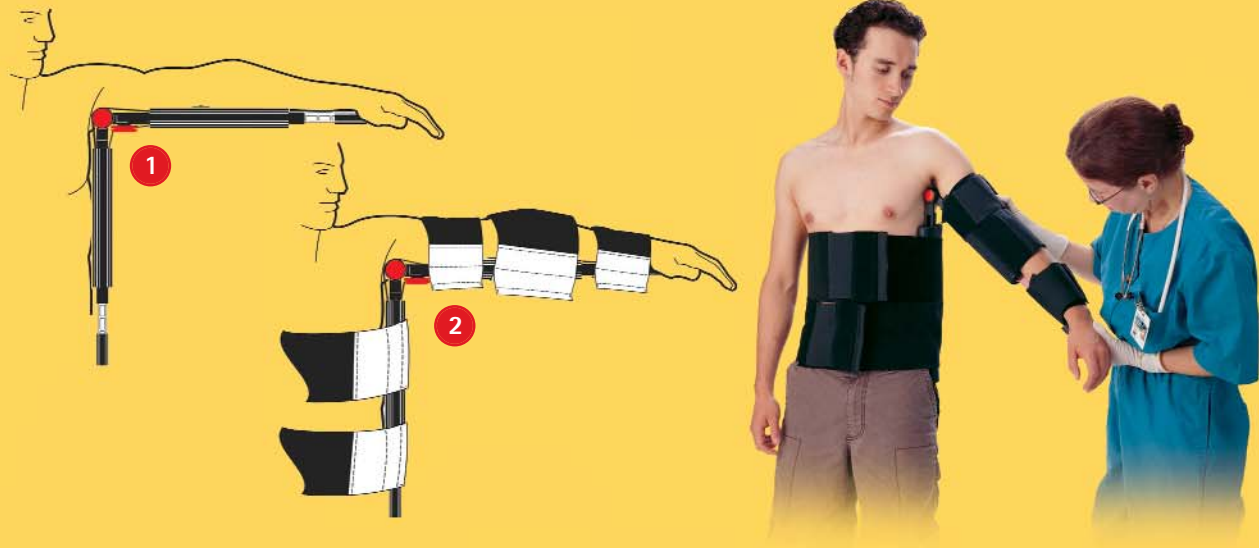

Dislocated Shoulder

- 1 Dislocation of shoulder splinted in position found.
- 2 Arm is immobilized.

Forearm Injury

- 3 Anterior view forearm injury.
- 4 Splinted forearm.

Fractured Wrist or Forearm

- 5 Immobilized wrist or forearm.

Fractured Elbow

- Distal pad can be rotated to fit in palm of the hand.
- 6 Splint position for fractured elbow.
- 7 Immobilized fractured elbow.



(PowerPoint #22, 23, 24)

Training application sheet #6: **SX405 Adaptor™** with all fracture response **SEFRS®** features, advantages and benefits.

Feature	Advantage	Benefit
Rapid Assembly, Rapid Application.	■ Assembles in under 15 seconds. Application on fracture in less than 2 minutes.	■ Fast Rescue, less pain.
Splints within the body silhouette.	■ No protruberances outside of silhouette.	■ Makes extrication from confined space of wreckage easier, less time consuming and with fewer complications.
Comprehensive Tensor Cravat System.	■ 3 widths, 16 lengths. Can be used to immobilize and compress, treat sprains, strains, contusions, flail chests, clavicle fractures, provide slings, control sucking chest wounds as well as temporarily compress and immobilize pelvic fractures. Can be disposed or cleaned and reused.	■ Enables cost effective immobilization. Ensures a universal fit.
Universal.	■ Will treat any fracture.	■ You always have the right equipment for any type of fracture, any size of patient.
Procedural Comfort. Variable range Adaptor (rotatable from 30 to 330 degrees).	■ "No Touch" method uses Adaptor™ to determine the fracture configuration. The Adaptor is then locked to retain the fracture configuration, removed and attached to the padded splint shafts. Once assembled, the device is then applied to the patient. Enables First Responder to splint in position found.	■ Allows First Responder to fashion splint before it is applied. No movement of fractures means less injury and pain.
Super durable composite plastic construction. X-ray and Cat Scan compatible.	■ Radio lucent design enables Xrays and Cat Scans to be taken without removing the splint.	■ Secure splinting from field to hospital.
Engineered for comfort and safety.	■ Splint padding consists of closed cell foam. Does not easily absorb fluids.	■ Easily cleaned and decontaminated.
Packaging.	■ Compact, robust and lightweight. Easily stored or carried in most backpacks. Folds into a 5" X 11" X 14" Carry Case. Tooled outline allows instant size identification and application in wind and rain.	■ Carry case has been designed to ensure easy transport as well as easy accessibility for accessories and components. Saves time and confusion when selecting appropriate cravats for various applications.

Section Eight:

Student examinations (ii)

Practical examination to apply the **SX405 Adaptor**[™].
Includes test paper and a certificate for successful candidates.

Practical Examination (ii)

SX405 Adaptor™ Complete Fracture Response System

Name: _____

Student i.d. #: _____

Date: _____

Course: _____

Questions 1 - 17, 2 points each.

- 1 The fracture response kit will splint any fracture in the human body in position found.
 True False
- 2 Security Cravats should only be applied when:
 (a) the patient is unconscious,
 (b) the patient is agitated due to brain injury,
 (c) the patient is uncooperative, or struggling and agitated due to brain injury or drug use, or
 (d) none of the above
- 3 Security Cravats should be placed:
 (a) only to splint a struggling patient without need of added stretchable cravats,
 (b) under stretchable cravats,
 (c) over stretchable cravats, or
 (d) only to immobilize a struggling or uncooperative patient
- 4 It is vitally important to monitor the patient when using the non-stretchable Security Cravats because there is a danger that they could create a tourniquet effect and should be removed as early as possible or be loosened or tightened consistent with good blood circulation if there is a continuing need.
 True False
- 5 The Adaptor™ should be disassembled to be cleaned.
 True False
- 6 An attempt should only be made to straighten a bent knee injury if:
 (a) pulses are absent,
 (b) pulses are absent and leg straightening is done without pain or resistant to movement,
 (c) the patient requests it, or
 (d) the patient doesn't complain about the injury

- 7 The **Adaptor**[™] is manipulated free of the patient and mimics the shape and angle of a fracture. To apply the **Adaptor**[™], the arms should be lightly placed or centered over the fracture site and the arms aligned with each side of the fracture. When applying the **Adaptor**[™], it is important to make sure that the arms are applied parallel to:
- (a) the muscle silhouette of the limb,
 - (b) the bone,
 - (c) both the bone and the muscle,
 - (d) none of the above
- 8 The **Adaptor's** lateral and vertical range of motion is:
- (a) 360°
 - (b) 90°
 - (c) 90° to 180° or,
 - (d) 30° to 330°
- 9 The fracture response kit is sized to treat any fracture in the human body on what size of patient;
- (a) infants, children and adults
 - (b) a child (age 6 +) to an adult 5'10"
 - (c) the 5th to 99th percentile of patients, or
 - (d) "a" and "b"
- 10 The fracture response **Adaptor**[™] and splint shafts allow treatment of all of fractures with traction.
- True False
- 11 It is necessary to turn each of the **Adaptor**[™] Knobs clockwise to unlock each of the rotatable arms.
- True False
- 12 The **Adaptor**[™] should be locked to retain the angle configuration prior to applying the padded splint shafts.
- True False
- 13 An assembled splint that was incorrectly configured to fit the injured limb can;
- (a) to save time have the locking knobs unlocked and the angles readjusted to conform to the injured limb then locked and reapplied,
 - (b) required to start all over, remove the padded arms, readjust the adaptor to the correct angle, reapply the padded arms, then reapply the splint, or,
 - (c) try moving the limb to conform to the splint.

14 Tensor Cravats can be placed over an open wound:

- True False

15 The total number Tensor Cravats used per injury should be:

- (a) two,
 (b) three or less,
 (c) as many needed to stabilize and support the limb, or,
 (d) no more than five.

16 It is important to splint in position found because:

- (a) it is excruciating painful,
 (b) the distal pulses are absent,
 (c), the joint is locked and immobile,
 (d) attempts to recover circulation by manipulation failed, or,
 (e) all of the above.

17 When splinting a fracture dislocation do you:

- (a) First straighten the limb out,
 (b) splint in position found,
 (c) all of the above,
 (d) use the security cravats in all cases,
 (e) none of the above.

Practical examination (ii): Answer key

SX405 Adaptor™ Complete Fracture Response System

Questions 1 - 17, 2 points each.

- 1 The fracture response kit will splint any fracture in the human body in position found; (True).
- 2 Security Cravats should only be applied when; (c) the patient is uncooperative, or struggling and agitated due to brain injury or drug use.
- 3 Security Cravats should be placed; (c) over stretchable cravats.
- 4 It is vitally important to monitor the patient when using the non-stretchable Security Cravats because there is a danger that they could create a tourniquet effect and should be removed as early as possible or be loosened or tightened consistent with good blood circulation if there is a continuing need; (True).
- 5 The Adaptor™ should be disassembled to be cleaned; (False).
- 6 An attempt should only be made to straighten a bent knee injury if; (b) pulses are absent and leg straightening is done without pain or resistant to movement.
- 7 The Adaptor™ is manipulated free of the patient and mimics the shape and angle of a fracture. To apply the Adaptor, the arms should be lightly placed or centered over the fracture site and the arms aligned with each side of the fracture. When applying the Adaptor, it is important to make sure that the arms are applied parallel to; (b) the bone.
- 8 The Adaptor's lateral and vertical range of motion is; (d) 30° to 330°.
- 9 The fracture response kit is sized to treat any fracture in the human body on what size of patient; (c) the 5th to 99th percentile of patients.
- 10 The fracture response Adaptor™ and splint shafts allow treatment of all of fractures with traction; (False).
- 11 It is necessary to turn each of the Adaptor Knobs clockwise to unlock each of the rotatable arms; (False).
- 12 The Adaptor™ should be locked to retain the angle configuration prior to applying the padded splint shafts; (True).
- 13 An assembled splint that was incorrectly configured to fit the injured limb can; (b) required to start all over, remove the padded arms, readjust the adaptor to the correct angle, reapply the padded arms, then reapply the splint.
- 14 Tensor Cravats can be placed over an open wound; (True).
- 15 The total number Tensor Cravats used per injury should be; (c) as many needed to stabilize and support the limb.
- 16 It is important to splint in position found because; (e) all of the above.
- 17 When splinting a fracture dislocation do you; (b) splint in position found.

Certification of completion

This certifies that: _____ has completed both practical and written examinations in the use of **SEFRS**[®] Sager Emergency Fracture Response System) and meets all local, state and federal requirements and certifications for use of this equipment.

Date awarded: _____

Awarded by: _____ *(name of EMS Instructor)*

On behalf of: _____ *(name of EMS Institution)*

State/County/Province: _____